



INSTRUCTION MANUAL

POLYKEG PRO



MI01 Rev. 07 dated 06/08/2020

This document is property of PolyKeg® S.r.l. - Unauthorized copying and use is strictly forbidden.

This manual contains information, instructions and warnings for proper handling and use of the PolyKeg PRO one-way keg.

	SECTION 1 Warnings	3		SECTION 7 POLYKEG PRO WITHOUT BAG Filling instructions with PolyKeg® manual kit	21
	SECTION 2 Packing and keg identification	5		SECTION 8 Tapping instructions	25
	SECTION 3 Valves and couplers	7		SECTION 9 Depressurization instructions	28
	SECTION 4 Logistics data sheet	9		SECTION 10 Dismantling instructions	30
	SECTION 5 Sanitizing instructions	14		SECTION 11 Materials and symbols sheet	34
	SECTION 6 POLYKEG PRO WITH BAG Filling instructions with PolyKeg® manual kit	16			



SECTION 1

Warnings

SECTION 1

Warnings



The PolyKeg PRO one-way keg is intended for **professional use only**. Please refer to this Instruction Manual and the symbols on the keg before use.

When handling the keg, wear personal **protective equipment** (goggles, gloves, etc.) and make sure the room where you are working is **ventilated**.

Make sure the keg is **intact** and leave the **warnings** on the keg clearly readable.

If used improperly the PolyKeg PRO keg may be damaged, not ensuring the integrity of the product or causing injury and/or property damage.

The PolyKeg PRO one-way keg **cannot be reused**, should **not be released into the environment** and should be **depressurised immediately** after use and disposed of empty at **authorised collection points**.

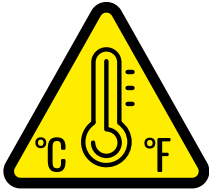

0÷35 °C - 32÷95 °F

Keep away from heat sources.

If exposed to temperatures above the permitted limit the keg may be damaged, not ensuring the integrity of the product or causing injury and/or property damage.



MAX 3.5 BAR - MAX 50 PSI

If over-pressurized, the keg may cause injury and/or property damage.

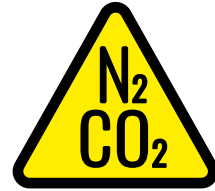

HAZARD

Suffocation hazard.
Use in a well-ventilated environment.



NO CHILDREN

Keep away from children.

When the keg is under pressure it is heavy and can cause injury and/or property damage.



NO DIRECT SUNLIGHT

Do not expose to direct sunlight.

The keg may be damaged, not ensuring the integrity of the product or causing injury and/or property damage.



NO CHEMICALS

Keep away from unsuitable chemicals or cleaning substances. The keg may be damaged, not ensuring the integrity of the product or causing injury and/or property damage.



DO NOT REMOVE

Do not remove and/or tamper with the valve. The keg may be damaged, not ensuring the integrity of the product or causing injury and/or property damage.



DO NOT ROLL

Do not roll and/or drop.
The keg may be damaged causing injury and/or property damage.



DO NOT PIERCE

Do not pierce and/or cut.
The keg may be damaged causing injury and/or property damage.



SECTION 2

Packing and keg identification

SECTION 2

Packing and keg identification



PALLET STANDARD IDENTIFICATION



VALVE AND KEG IDENTIFICATION

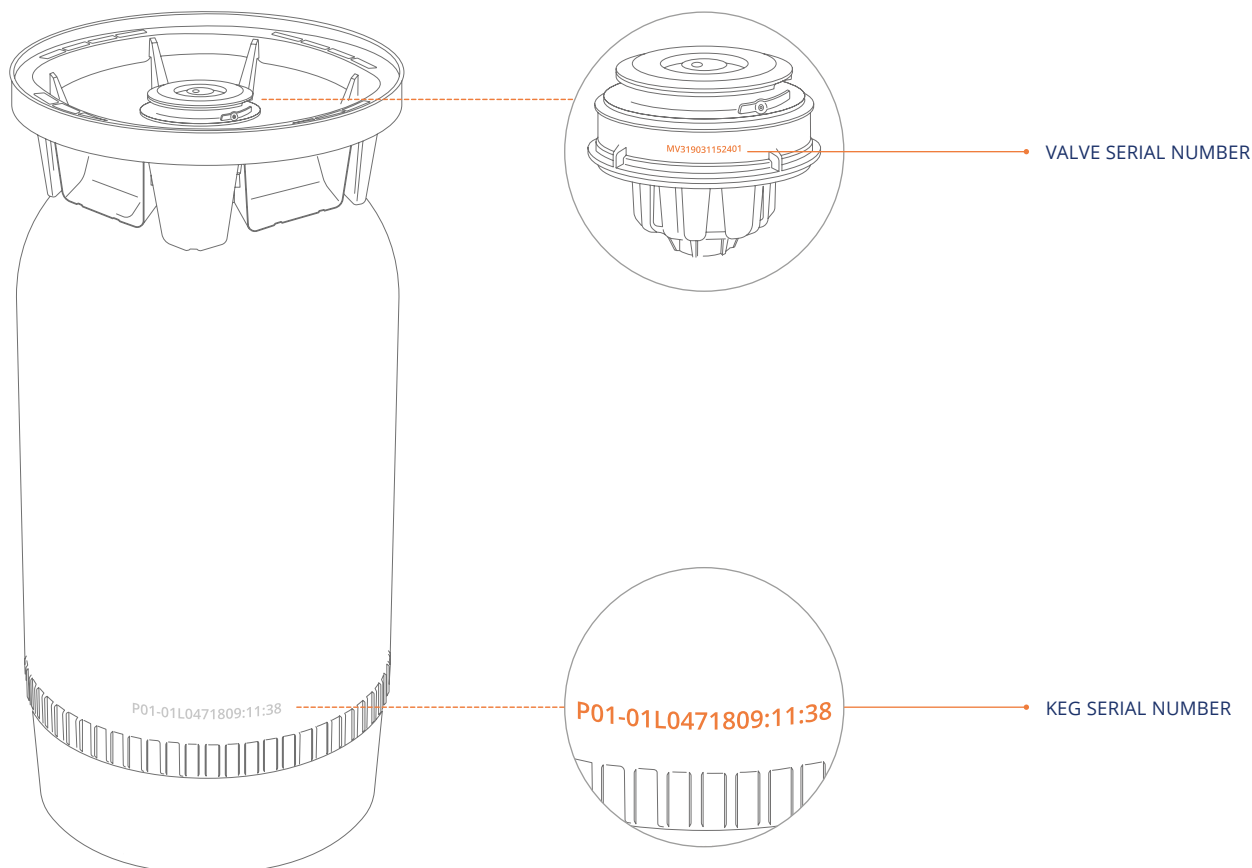



















SECTION 3

Valves and couplers

SECTION 3

Valves and couplers

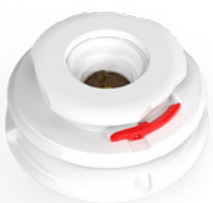

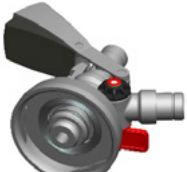
TYPE	VALVE	COUPLER		NOTES
A				Flat
G				
M				
S				European Sankey
D				American Sankey
K				FK



SECTION 4

PolyKeg[®] PRO logistics data sheets

SECTION 4

PolyKeg® PRO logistics data sheets



EMPTY KEGS PALLETIZATION

PALLET 80X120 CM | 31.50"X47.24"

Palletization						
		12 L	16 L	20 L	24 L	30 L
		406 oz.	541 oz.	676 oz.	811 oz.	1014 oz.
Layers		5	4	4	4	4
Kegs per layer		15	15	15	12	11
Kegs per pallet		75	60	60	48	44
Height		2077 mm 81,77"	2044 mm 51,91"	2396 mm 94,33"	2384 mm 93,85"	2384 mm 93,85"
QUANTITY						
	pallet	kegs	kegs	kegs	kegs	kegs
CTR 20 ft Standard	11	825	660	495*	396*	363*
CTR 40 ft High Cube	24	1800	1440	1440	1152	1056
CTR 45 ft High Cube	32	2400	1920	1920	1536	1408
Truck 13,6 mt	32	2400	1920	1920	1536	1408

PALLET 100X120 CM | 39.37"X47.24"

Palletization						
		12 L	16 L	20 L	24 L	30 L
		406 oz.	541 oz.	676 oz.	811 oz.	1014 oz.
Layers		5	4	4	4	4
Kegs per layer		20	20	20	16	12
Kegs per pallet		100	80	80	64	48
Height		2077 mm 81,77"	2044 mm 51,91"	2396 mm 94,33"	2384 mm 93,85"	2384 mm 93,85"
QUANTITY						
	pallet	kegs	kegs	kegs	kegs	kegs
CTR 20 ft Standard	10	1000	800	600*	480*	360*
CTR 40 ft High Cube	22	2200	1760	1760	1408	1056
CTR 45 ft High Cube	26	2600	2080	2080	1664	1248
Truck 13,6 mt	26	2600	2080	2080	1664	1248

WARNINGS

Possibility of stacking pallets and the maximum number of layers must take into account the mechanical properties of the keg as specified on the technical data sheet, local regulations, means of transport, handling methods of handling, as well as the conditions of storage areas. Kegs are supplied on pallets, wrapped with white extensible film for better protection.

*Quantities refer to three layers palletization, compulsory for CTR 20 ft Standard.

SECTION 4

PolyKeg® PRO logistics data sheets



FILLED KEGS PALLETIZATION

PALLET 80X120 CM | 31.50"X47.24"

Palletization										
	12 L	406 oz.	16 L	541 oz.	20 L	676 oz.	24 L	811 oz.	30 L	1014 oz.
Layers	3*		2*		2*		2*		2*	
Kegs per layer	15		15		15		12		11	
Kegs per pallet	45		30		30		24		22	
Height	1307 mm 51,45"		1098 mm 43,22"		1274 mm 50,15"		1268 mm 49,92"		1268 mm 49,92"	
Stacking in storage										
Layers	3+3		2+2		2+2		2+2		2+2	
Stacking for transport										
Layers	3+2		2+2		2+1		2+1		2+1	

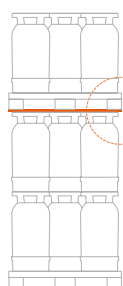

Wooden interlayer

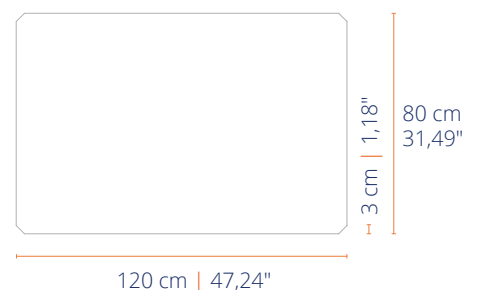
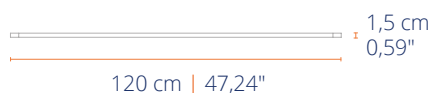

WARNINGS*

Possibility of stacking pallets and the maximum number of layers must take into account the mechanical properties of the keg as specified on the technical data sheet, local regulations, means of transport, handling methods of handling, as well as the conditions of storage areas. To overlap pallets, the load must be evenly distributed using either a rigid interlayer or an inverted pallet. It is recommended to wrap the kegs on pallets with white extensible film for better protection.

SECTION 4

PolyKeg® PRO logistics data sheets



FILLED KEGS PALLETIZATION

PALLET 100X120 CM | 39.37"X47.24"

Palletization					
	12 L 406 oz.	16 L 541 oz.	20 L 676 oz.	24 L 811 oz.	30 L 1014 oz.
Layers	3*	2*	2*	2*	2*
Kegs per layer	20	20	20	16	12
Kegs per pallet	60	40	40	32	24
Height	1307 mm 51,45"	1098 mm 43,22"	1274 mm 50,15"	1268 mm 49,92"	1268 mm 49,92"
Stacking in storage					
Layers	3+3	2+2	2+2	2+2	2+2
Stacking for transport					
Layers	3+2	2+2	2+1	2+1	2+1

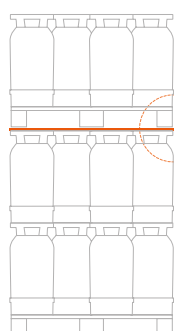

Wooden interlayer

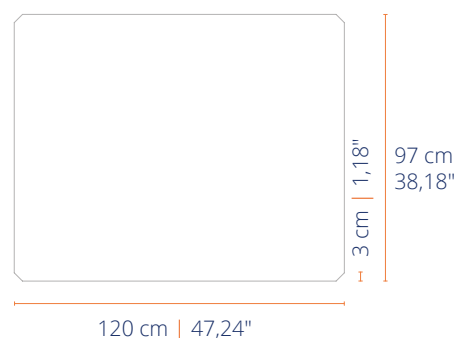
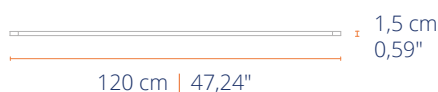

WARNINGS*

Possibility of stacking pallets and the maximum number of layers must take into account the mechanical properties of the keg as specified on the technical data sheet, local regulations, means of transport, handling methods of handling, as well as the conditions of storage areas.

To overlap pallets, the load must be evenly distributed using either a rigid interlayer or an inverted pallet. It is recommended to wrap the kegs on pallets with white extensible film for better protection.

SECTION 4

PolyKeg® PRO logistics data sheets



LOADING RECOMMENDATIONS

PALLET 80X120 CM | 31.50”X47.24”

	pallet	plan view
CTR 20 ft Standard	11	
CTR 40 ft High Cube	24	
CTR 45 ft High Cube	32	
Truck 13,6 mt	32	

PALLET 100X120 CM | 39.37”X47.24”

	pallet	plan view
CTR 20 ft Standard	10	
CTR 40 ft High Cube	22	
CTR 45 ft High Cube	26	
Truck 13,6 mt	26	

WARNINGS

When transporting filled kegs, it is recommended to use refrigerated containers.

When using refrigerated containers, the number of pallets may vary.

To overlap pallets, the load must be evenly distributed using either a rigid interlayer or an inverted pallet. In order to prevent damage to the kegs and/or falls, the pallets must be secured with straps and airbags must be inserted in the empty spaces.

The maximum number of layers/kegs must consider the mechanical properties of the kegs as indicated on the technical data sheets, local regulations, means of transport and handling methods, as well as the condition of the storage facilities.



SECTION 5

Sanitizing instructions

SECTION 5

Sanitizing instructions



WHAT NEEDS TO BE SANITIZED

Before starting the filling, sanitize the manual filling kit (tubes, valves, seals, couplers, etc.) or the automatic/semi-automatic fill-ing machine. Before connecting the keg, clean and sanitize all parts likely to come into contact with the product (coupler and external part of the valve). After each filling, clean and sanitize the keg valve. Should it be necessary to temporarily disconnect the keg, clean and sanitize the external part of the valve.

Note We do not recommend the use of chemicals not mentioned in the user manual. Please pay attention to the composition of the chosen product.

SANITIZATION WITH MANUAL FILLING KIT

Peracetic acid solution in demineralised water



Min **1%**
Max **2%**



Min time
30 SECONDS

OR

Hydroalcoholic solution in demineralised water



Min **20%**
Max **50%**



Min time
45 SECONDS

SANITIZING THE POLYKEG MANUAL FILLING KIT

Soak the disassembled components of the manual filling kit in one of the sanitizing solutions listed above. Please follow the above dilution rates and timescales.

SANITIZING OF THE COUPLER AND THE EXTERNAL PART OF THE VALVE

Clean and spray the external surface of the components with one of the sanitizing solutions listed above. Please follow the above dilution rates and timescales.

SANITIZING WITH AUTOMATIC AND SEMI-AUTOMATIC MACHINES

Hot water



Maximum pressure on the valve
0,8 BAR



Maximum temperature
85°C



Max time
5 SECONDS

OR

Steam



Maximum pressure on the valve
0,8 BAR



Maximum temperature
100°C



Max time
3 SECONDS

AUTOMATIC/SEMI-AUTOMATIC MACHINE SANITIZING

Before starting the filling sanitize the automatic/semi-automatic filling machine.

SANITIZING THE EXTERNAL PART OF THE VALVE

Set the filler to sanitize the external surface of the keg valve with hot water or steam according to the above mentioned pressure, temperature and time values.



SECTION 6

POLYKEG PRO WITH BAG

Filling instructions with
PolyKeg[®] manual kit

SECTION 6

POLYKEG PRO WITH BAG

Filling instructions with PolyKeg® manual kit



Before filling, please refer to the warnings in the "Section 1" of the PolyKeg PRO instruction manual and to the keg technical data sheets.

- 1 Gas tube
- 2 Pressure top-up connection
- 3 Pressure top-up gauge
- 4 Pressure gauge
- 5 Gas regulator connection
- 6 Counter-pressure regulator
- 7 Product tube
- 8 Product filling connection
- 9 Product filling valve
- 10 Keg coupler (Micro Matic is recommended)

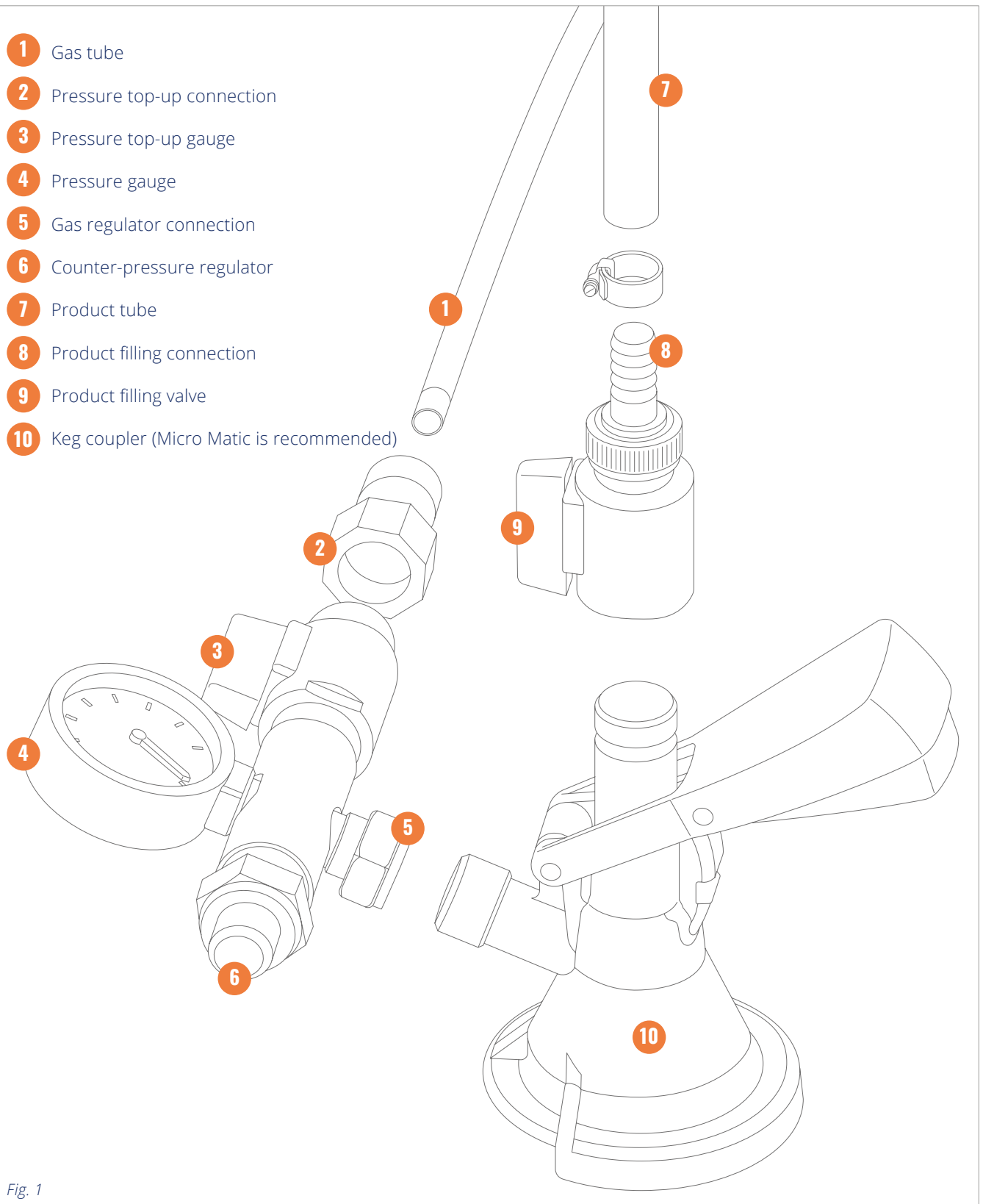

Fig. 1

SECTION 6

POLYKEG PRO WITH BAG

Filling instructions with PolyKeg® manual kit



PREPARATION

1. Sanitizing



Disassemble the PolyKeg® filling kit and sanitize the components as indicated in the “Sanitizing Instructions” section.

2. Assembly

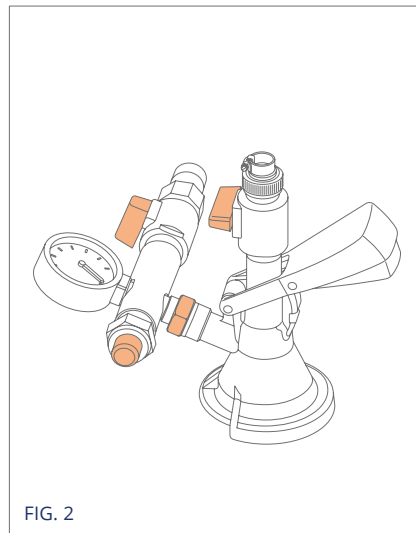

Reassemble the kit properly and close all valves.

3. Gas and product pressure check

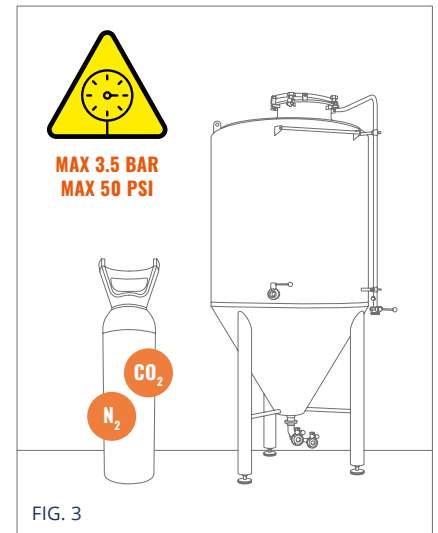

Check that the pressures of the filling system are correctly set and below the maximum value indicated. (3.5 bar).

4. Gas and product tube connection

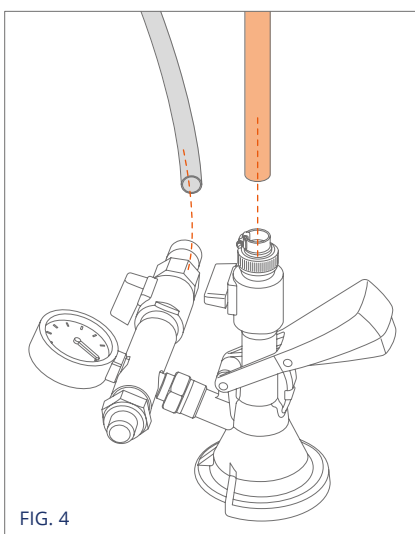

Connect the product and gas tubes to the filling kit.

5. Gas and product tubes connection with K-valve

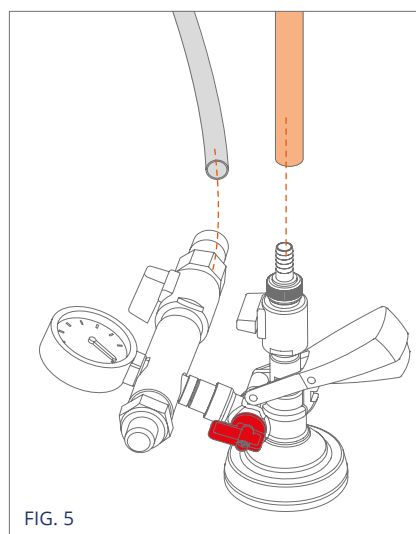

K-VALVE ONLY
Connect the product and gas tubes to the filling kit. Open the red valve.

6. Product tube purging

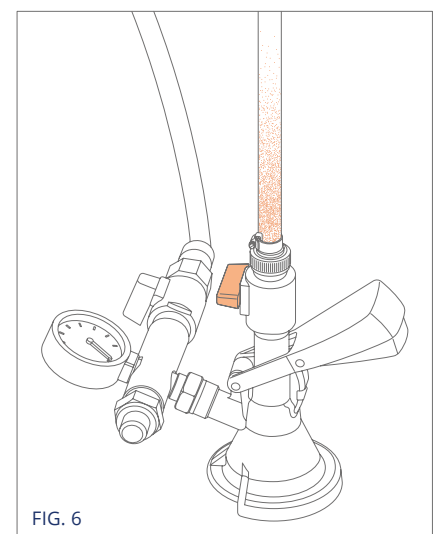

Work with the product valve to remove any residual gas from the product tube. Close the product valve.

SECTION 6

POLYKEG PRO WITH BAG

Filling instructions with PolyKeg® manual kit



FILLING

7. Sanitizing

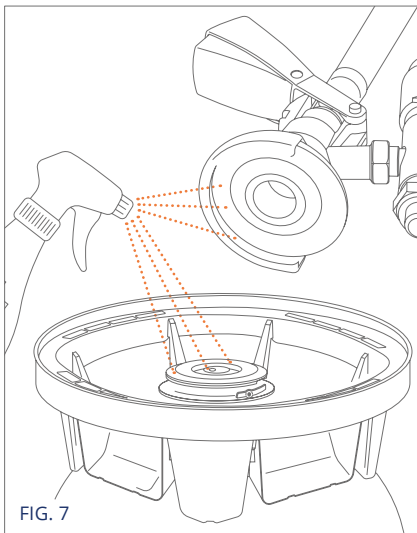

Before filling, sanitize the parts in contact with the product as indicated in the "Sanitizing instructions" section.

8. Connection and Counter-Pressure Check

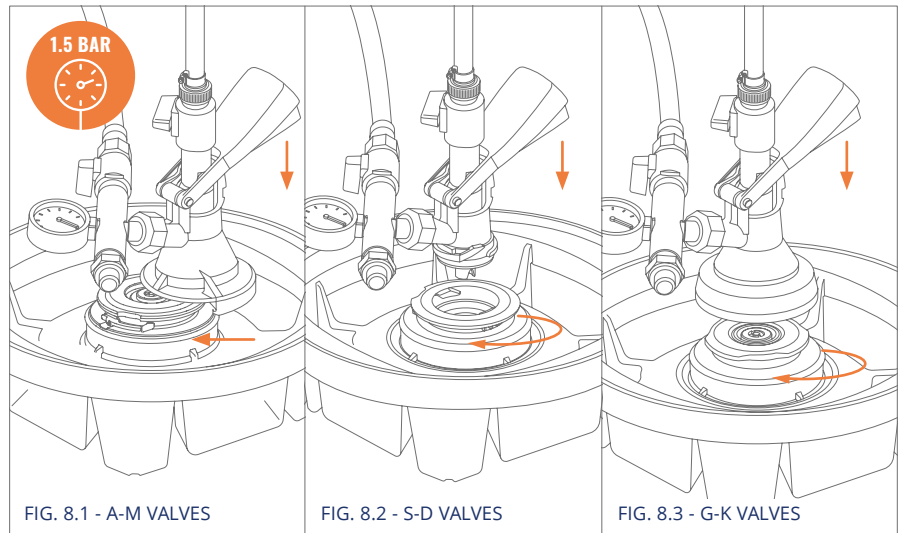

Make sure the filling head is properly connected to the valve, lower the lever and check the internal pressure of the keg.

9. Counter-pressure regulation

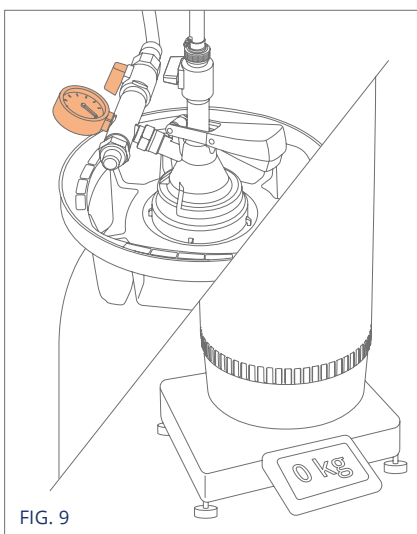

Work with the gas valve until the desired counter pressure is reached (approx. 0.5 bar lower than the product filling pressure).

10. Filling

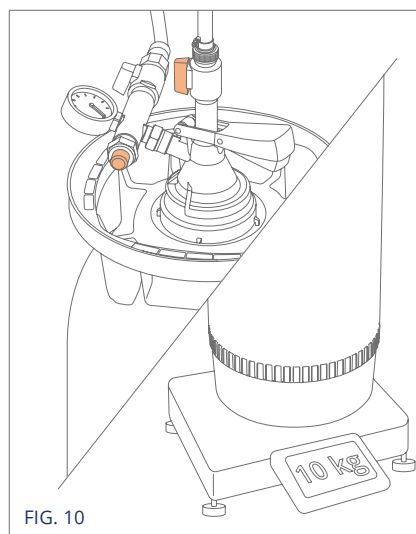

Open the product valve to start filling and work with the counterpressure regulator to set and/or change the filling speed.

11. End of filling

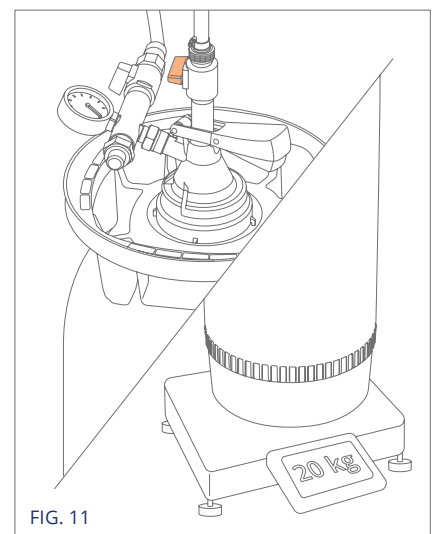

Once the nominal filling volume is reached, close the product valve. Do not exceed the nominal filling volume to prevent the product from leaking out of the bag.

SECTION 6

POLYKEG PRO WITH BAG

Filling instructions with PolyKeg® manual kit



12. Pressure balance

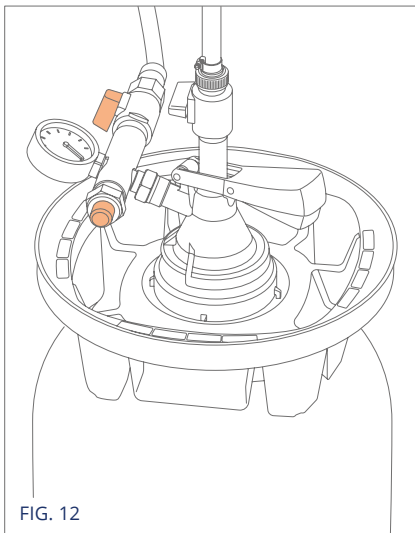

FIG. 12

Close the regulator and work on the gas valve to increase the counter-pressure to a value slightly higher than the product filling value.

13. Uncoupling

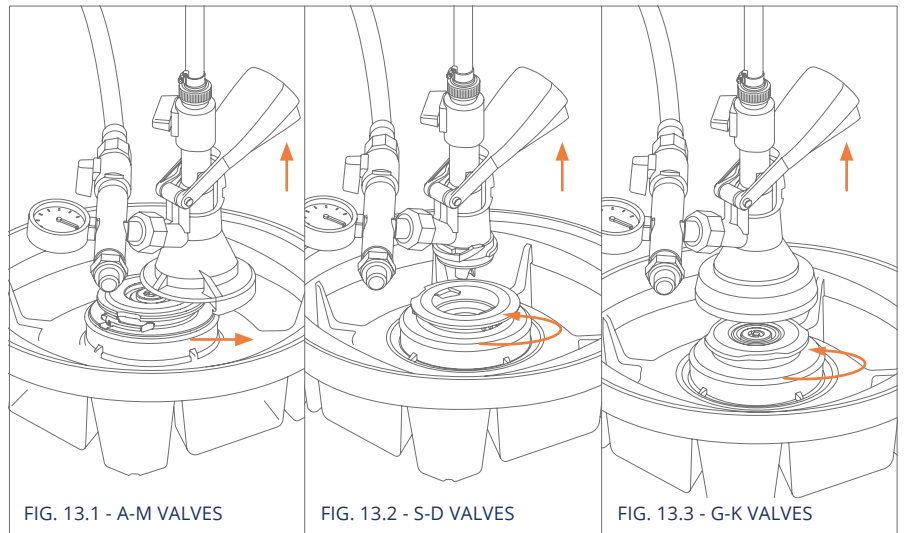

FIG. 13.1 - A-M VALVES

FIG. 13.2 - S-D VALVES

FIG. 13.3 - G-K VALVES

Quickly lift the lever and disconnect the coupler from the keg.

14. Valve sanitizing

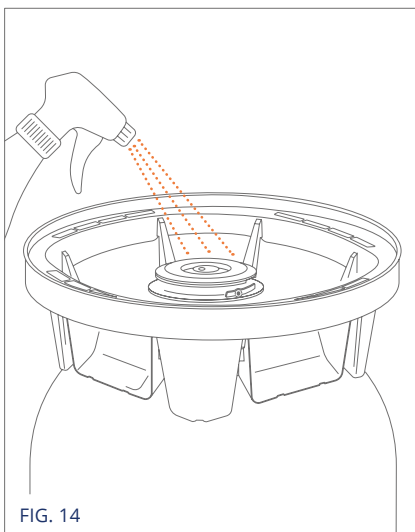

FIG. 14

Remove any residual product with water and sanitize the external part of the valve as indicated in the "Sanitizing instructions" section.

15. Seal application

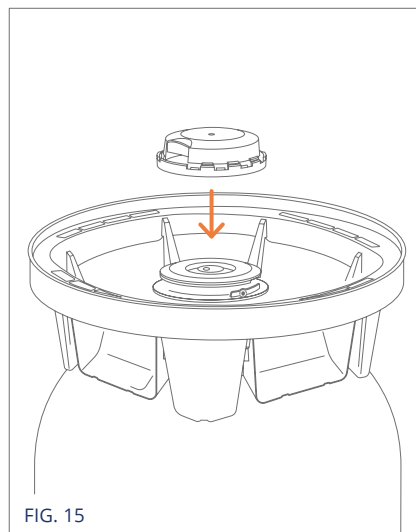

FIG. 15

Apply the seal.



SECTION 7

POLYKEG PRO WITHOUT BAG Filling instructions with PolyKeg[®] manual kit

SECTION 7

POLYKEG PRO WITHOUT BAG

Filling instructions with PolyKeg® manual kit



Before filling, please refer to the warnings in "Section 1" of the PolyKeg PRO instruction manual and to the keg technical data sheet.

PREPARATION

1. Sanitizing

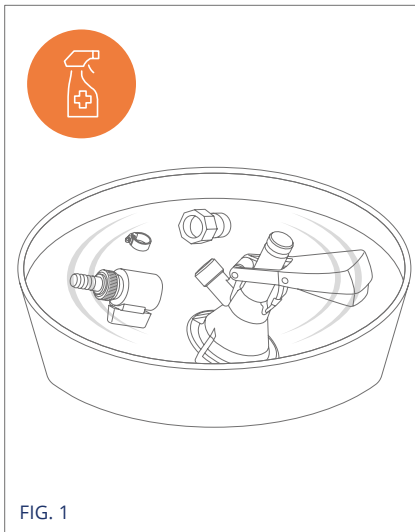

Disassemble the PolyKeg® filling kit and sanitize the components shown in the picture, following the sanitizing instructions found in "Section 5".

2. Assembly

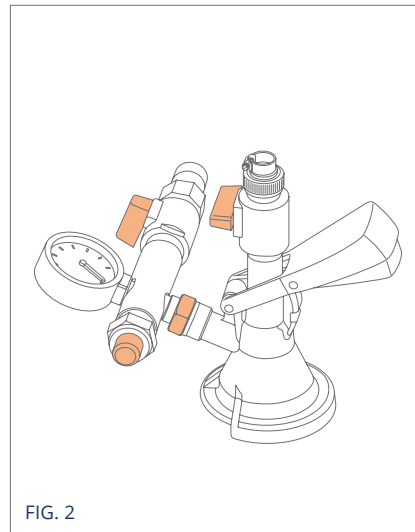

Reassemble the kit properly and close all valves.

3. Gas and product pressure check

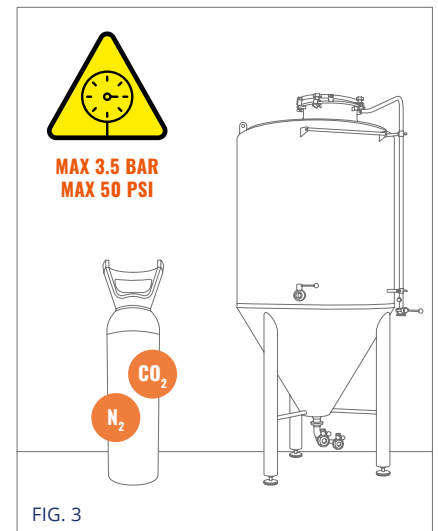

Check that both product and gas pressure in the tank does not exceed the maximum nominal working pressure (3.5 bar).

4. Gas and product tubes connection

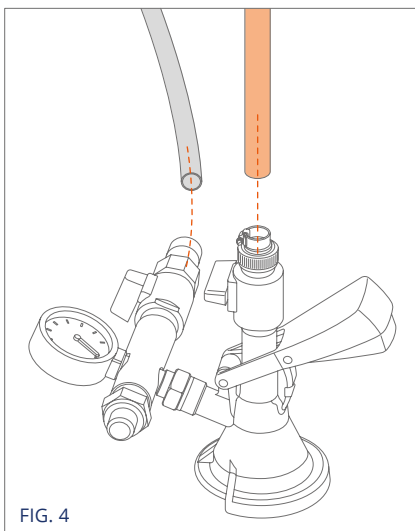

Connect the product and gas tubes to the filling kit.

5. Gas and product tubes connection with K valve

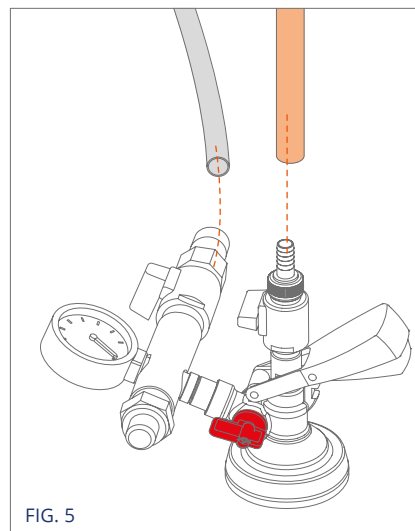

K VALVE ONLY
Connect the product and gas tubes to the filling kit. Open the red valve.

6. Product tube bleeding

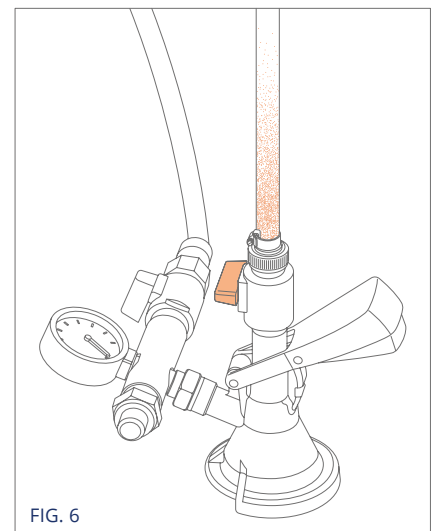

Work with the product valve to remove any residual gas from the product tube. Close the product valve.

SECTION 7

POLYKEG PRO WITHOUT BAG

Filling instructions with PolyKeg® manual kit



FILLING

7. Sanitizing

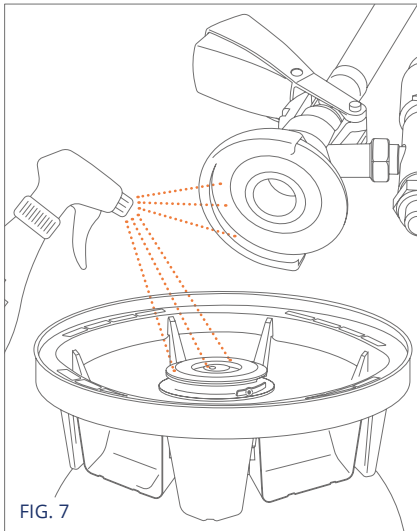

FIG. 7

Before filling, sanitize the parts in contact with the product according to the "Sanitizing Instructions" section.

8. Filling head connection and counter-pressure check

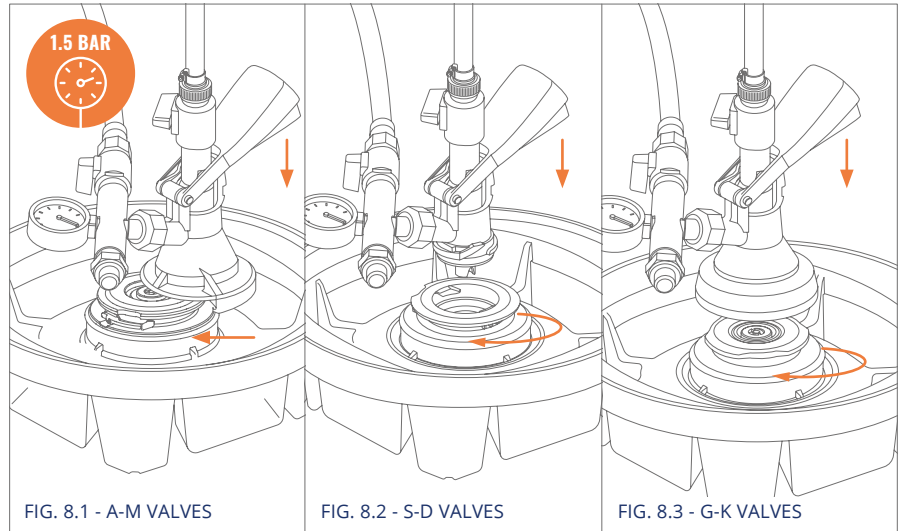

FIG. 8.1 - A-M VALVES

FIG. 8.2 - S-D VALVES

FIG. 8.3 - G-K VALVES

Connect properly the filling head to the valve, lower the lever and check the internal keg pressure.

9. Counter-pressure regulation

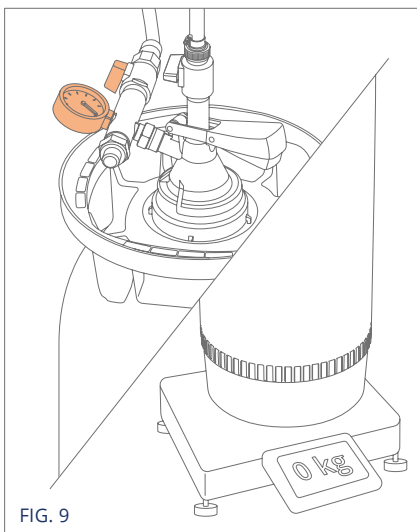

FIG. 9

Work with the gas valve until the desired counter-pressure is reached (approx. 0.5 bar lower than the product filling pressure).

10. Filling

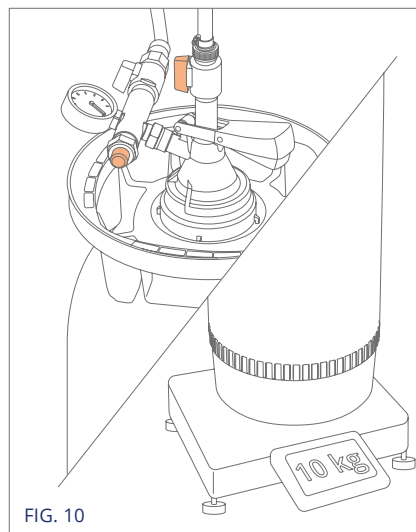

FIG. 10

Open the product valve to start filling and work with the counterpressure regulator to set and/or change the filling speed.

11. End of filling

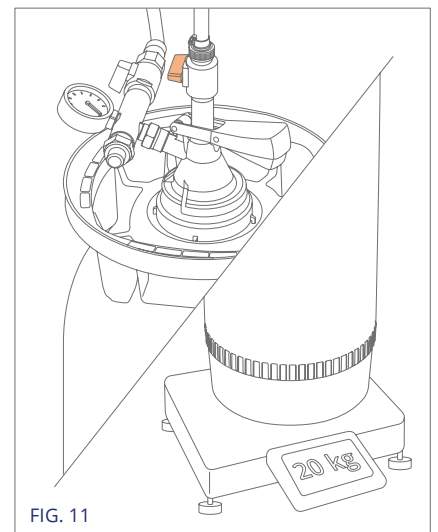

FIG. 11

Once the nominal filling volume is reached, close the product valve. Do not exceed the nominal filling volume to prevent the product from leaking.

SECTION 7

POLYKEG PRO WITHOUT BAG

Filling instructions with PolyKeg® manual kit



12. Uncoupling

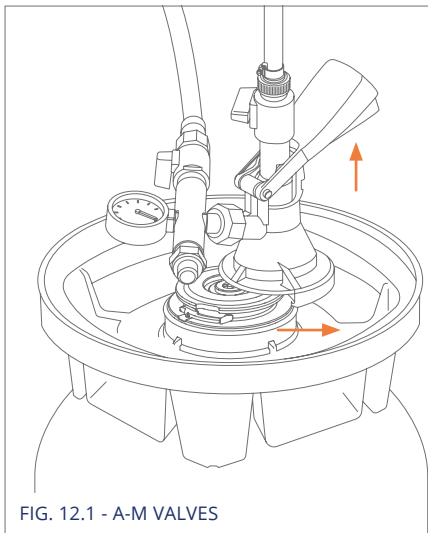

FIG. 12.1 - A-M VALVES

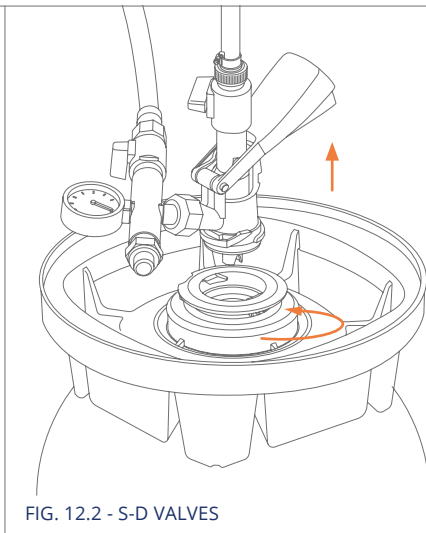

FIG. 12.2 - S-D VALVES

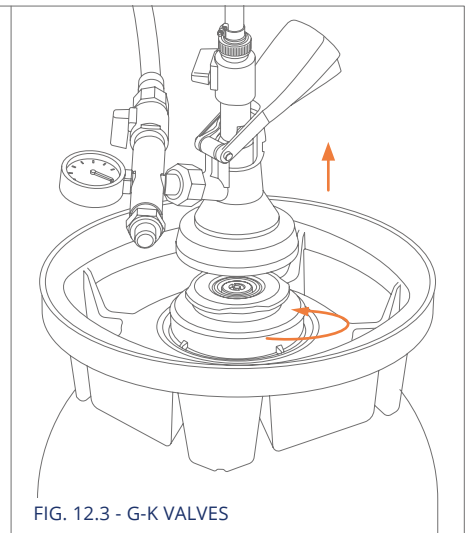

FIG. 12.3 - G-K VALVES

Quickly lift the lever and disconnect the coupler from the keg.

13. Valve sanitizing

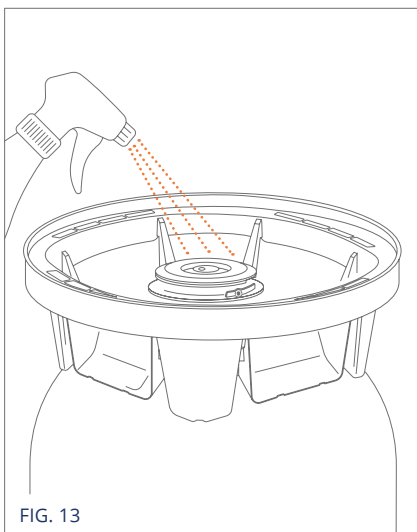

FIG. 13

Remove any residual product with water and sanitize the external part of the valve as per the "Sanitization instructions" section.

14. Seal Application

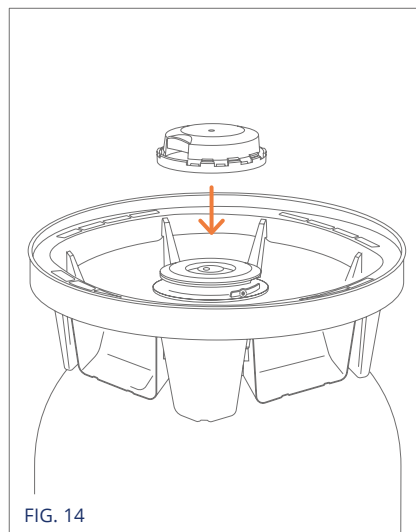

FIG. 14

Apply the keg seal.



SECTION 8

Tapping instructions

SECTION 8

Tapping instructions



When handling the keg, please wear personal protective equipment (goggles, gloves, etc.) and make sure the room where you are working is ventilated, as specified in the “Warnings” section.

The tapping system must be equipped with a pressure regulator and a properly calibrated safety valve.

Always make sure that the setting and working pressures of your tapping system are correctly set and do not exceed the maximum nominal value, as stated in the “Warnings” section.

TAPPING PROCEDURE

1. Pressure check

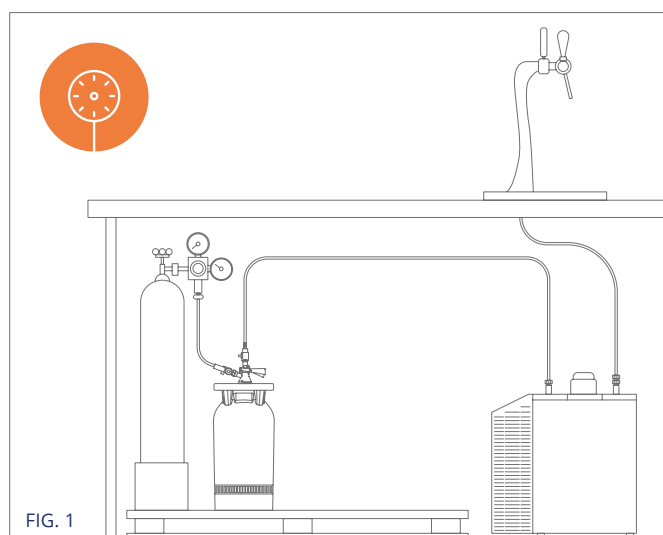

Before connecting the keg, please check that the tapping system is in order, sanitized and that the pressures are set correctly.

2. Sanitizing

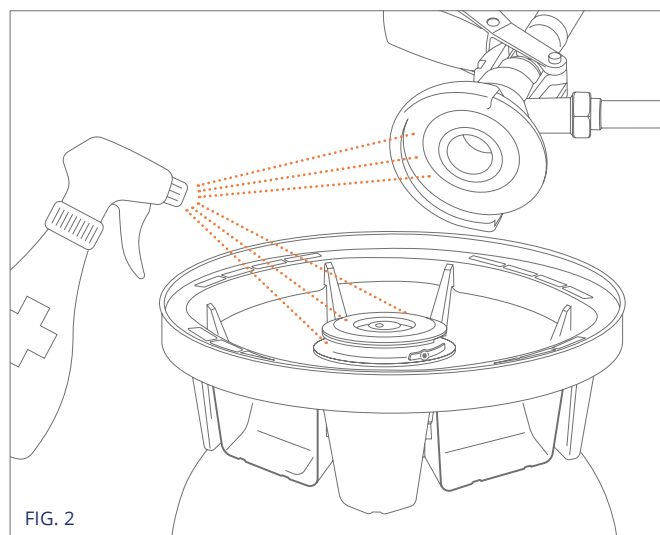

Sanitize the coupler surface that is in contact with the product, remove the seal and sanitize the external part of the valve, as mentioned in the “Sanitizing instructions” section.

3. Connection

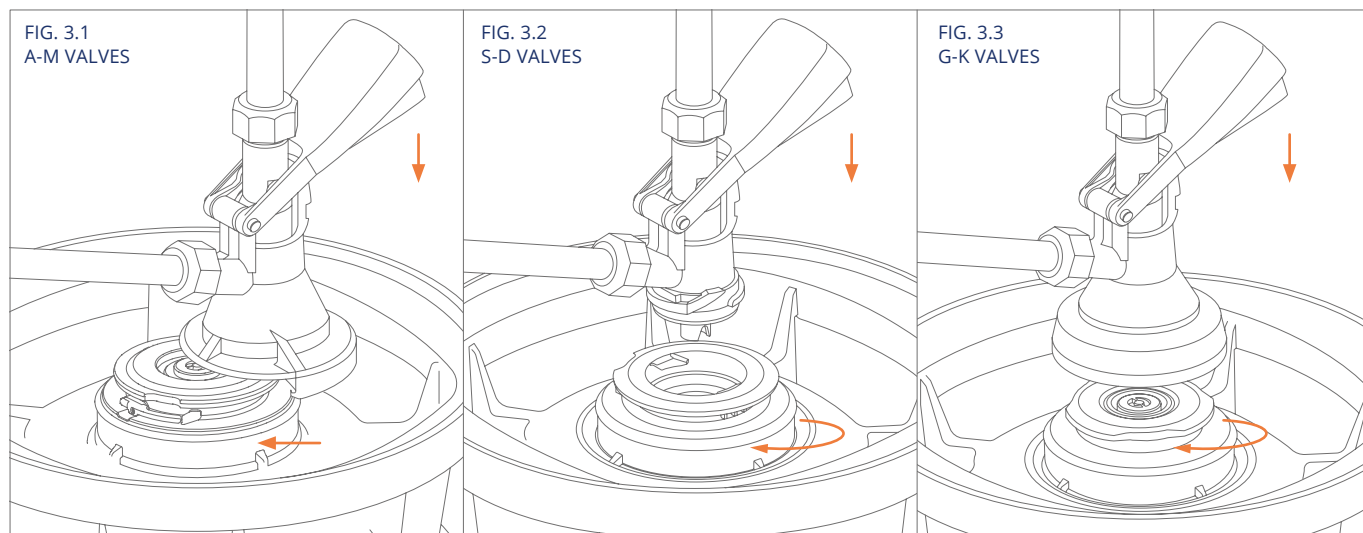

Connect the coupler to the keg valve and start tapping.

SECTION 8

Tapping instructions



4. Uncoupling

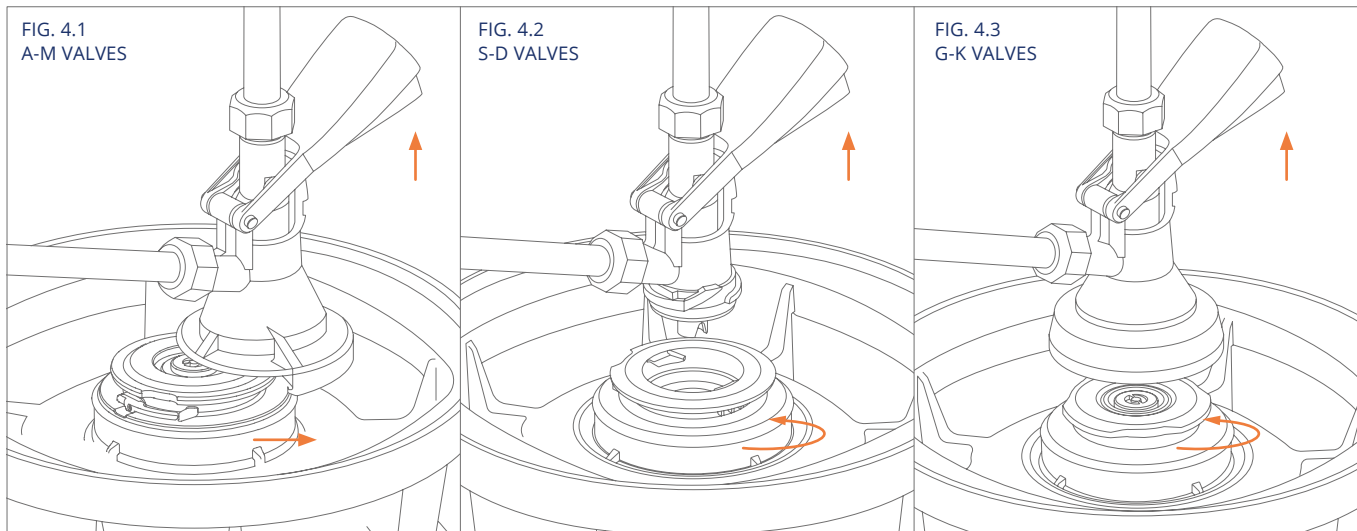

Once empty, disconnect the keg from the tapping system.

5. Empty keg management

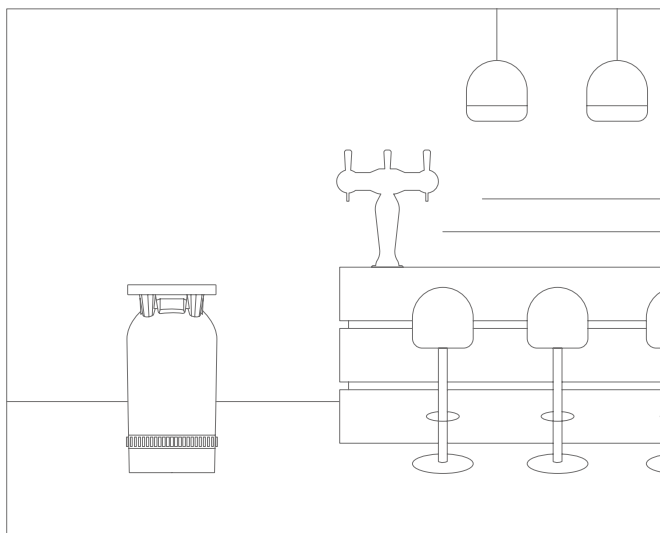

Disconnect the empty keg from the tapping system and proceed with its depressurization, as indicated in the "Depressurization Instructions" section.

Should it be necessary to temporarily disconnect the keg, clean and sanitize the valve as shown in the "Sanitizing instructions" section. Handle and store the keg according to the instructions in the "Warnings" section.

To start tapping again, repeat the procedure from step 1.



SECTION 9

Depressurization instructions

SECTION 9

Depressurization instructions



When handling the keg, please wear personal protective equipment (goggles, gloves, etc.) and make sure the room where you are working is ventilated, as mentioned in the “Warnings” section.

1. Depressurization procedure with PRV

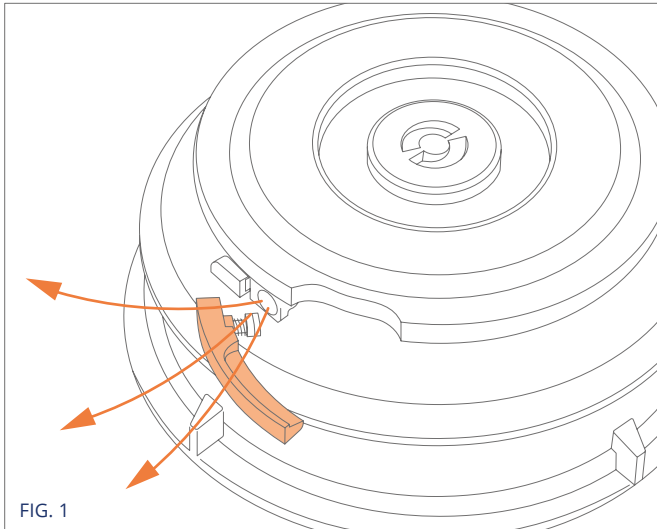

Once tapped, the empty keg must be depressurized immediately by breaking off the red PRV – pressure relief valve - lever.

2. Depressurization procedure without PRV

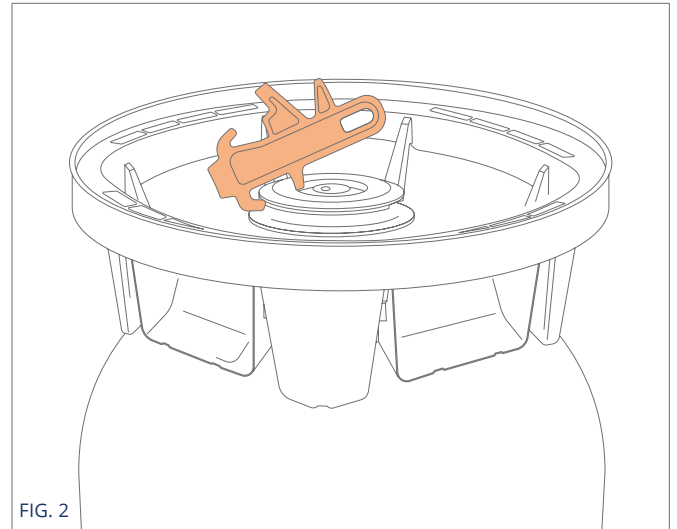

If the keg has no PRV, please use the dedicated depressurization key. It is suitable for all types of PolyKeg® valves: A, D, G, K, M, S.



SECTION 10

Dismantling instructions

SECTION 10

Dismantling instructions



- 1 Base locking system
- 2 Bag cutter and tube/bag neck unhooking device
- 3 Valve removal ring
- 4 Dismantling key

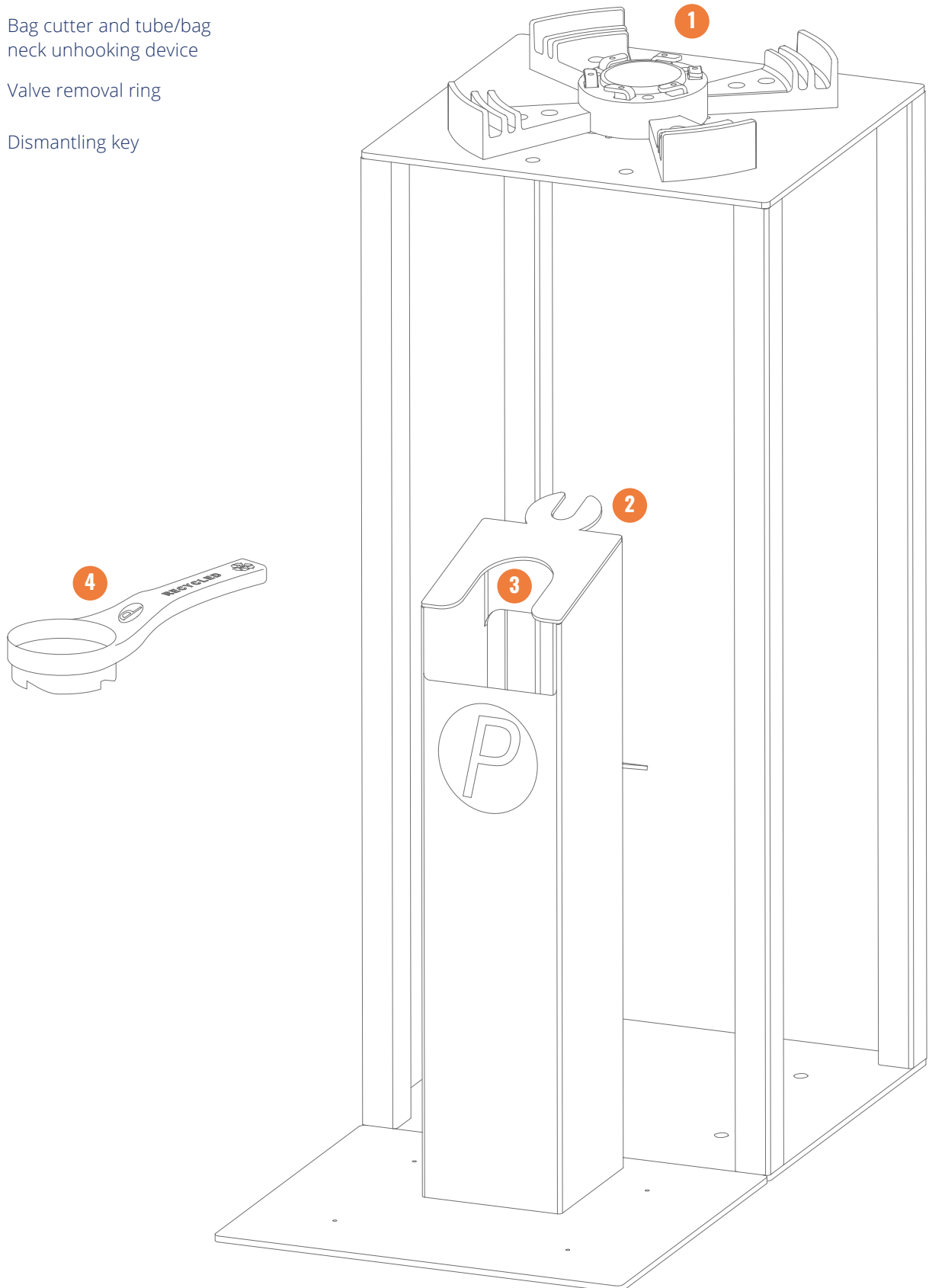

SECTION 10

Dismantling instructions



The keg must be depressurized immediately after use and in all cases before being dismantled.

The PolyKeg PRO keg can be easily dismantled as shown below, in order to make the materials recycling easier (please refer to the "Materials sheet").

DISMANTLING PROCEDURE

1. Keg locking

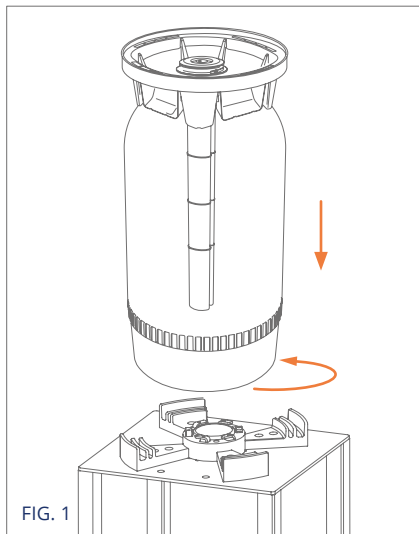

FIG. 1

Hook the depressurized keg to the device surface.

2. Valve removal

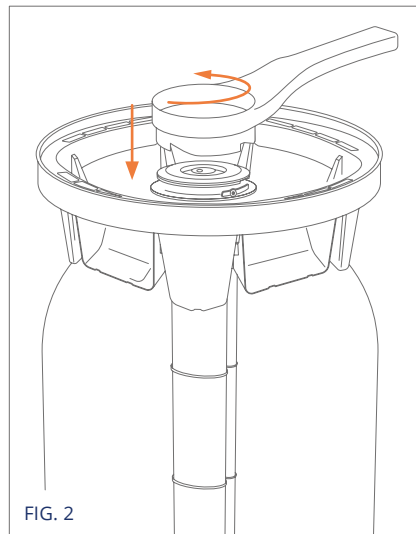

FIG. 2

Unscrew the valve using the dedicated dismantling key.

3. Valve extraction with dip tube or bag kit

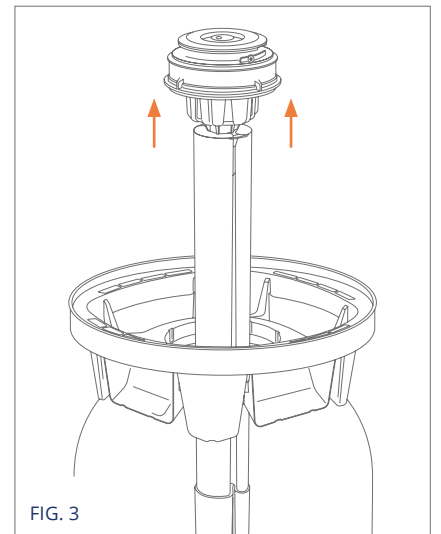

FIG. 3

Pull out of the bottle the valve and the dip tube, or the valve and the bag kit.

4. Valve from dip tube or from bag kit separation

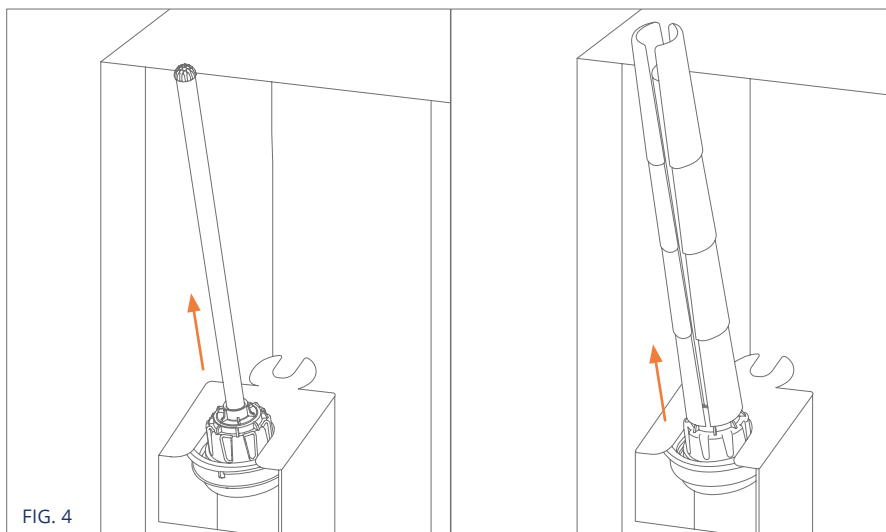

FIG. 4

Hook the valve to the ring and then detach it from the dip tube or from the bag kit.

5. Dip tube from bag separation

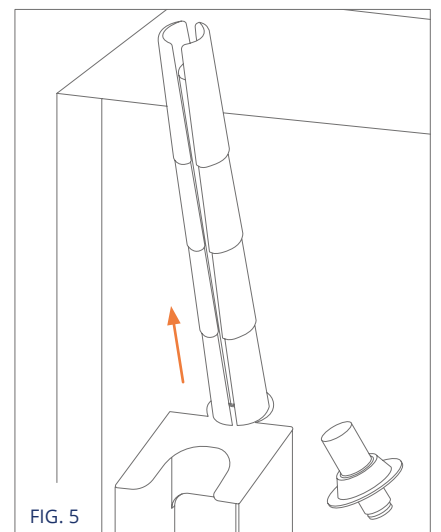

FIG. 5

Hook the bag kit to the ring and separate the dip tube and bag from the bag neck.

SECTION 10

Dismantling instructions



6. Handle removal

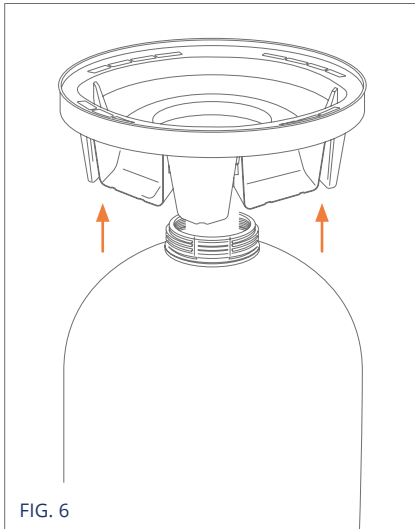

Remove the keg handle.

7. Base removal

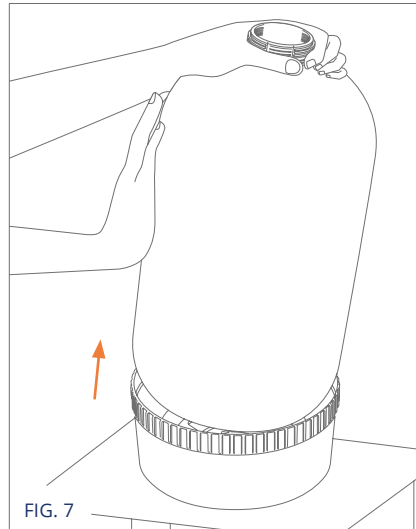

Push the bottle until the base comes off.

8. Base unlocking

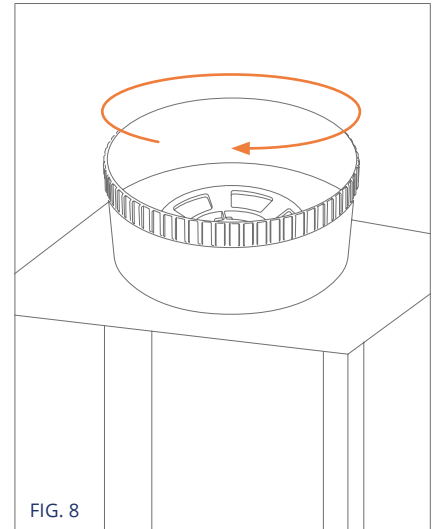

Unhook the base of the keg from the device surface.

10. Sorted keg components

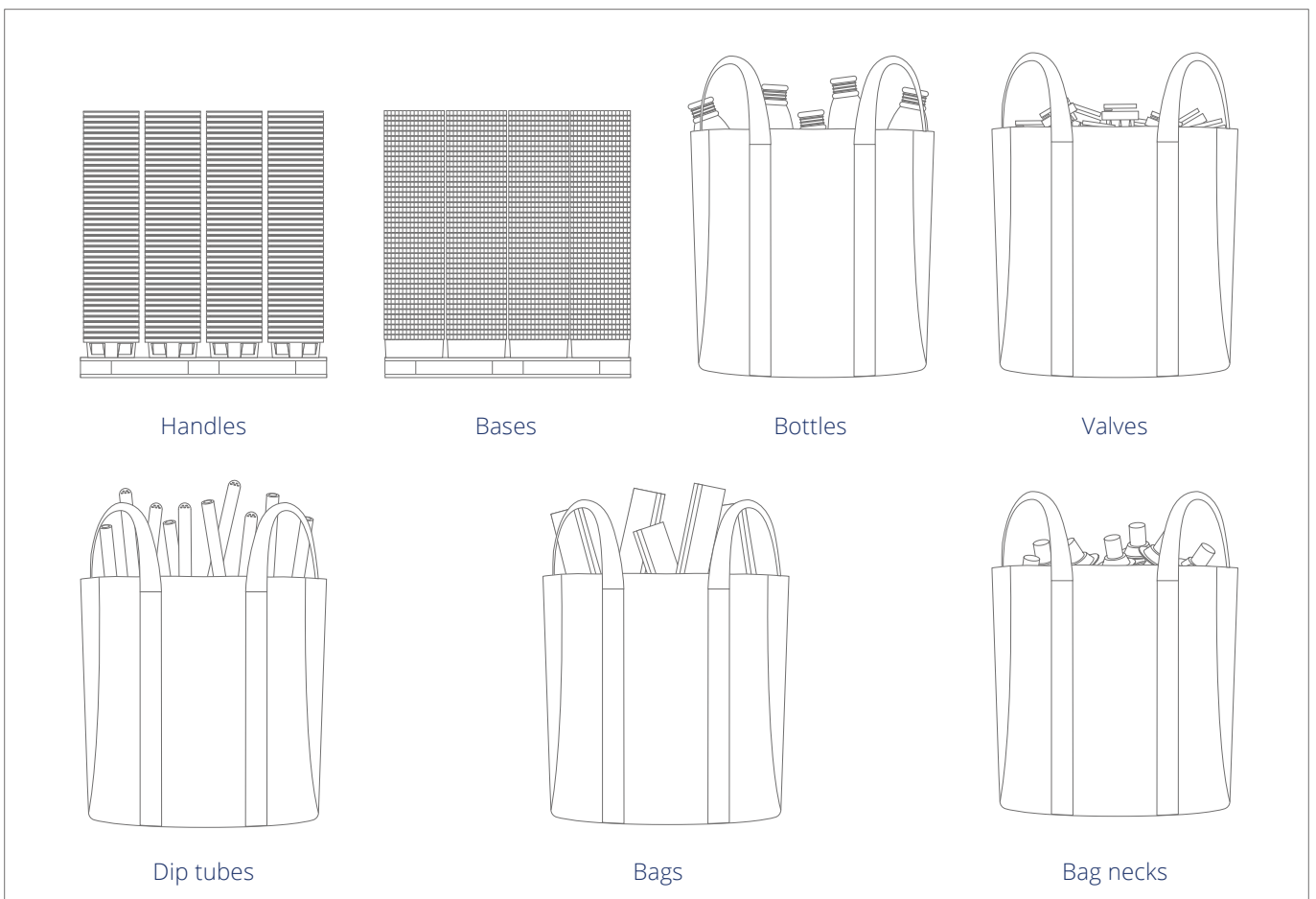

Store the keg components in appropriate boxes at the end of each step.



SECTION 11

Materials and symbols sheet

SECTION 11

Materials and symbols sheet



Below you can find the list of materials and related symbols according to the requirements defined by Directive 94/62/EC (art. 8) and based on the European Community Decision 97/129/EC.

1. POLYKEG PRO WITH BAG

Component	Material	Symbol
1 Seal	PP	
2 Valve	Other plastic	
3 Handle	PP	
4 Bag kit	PP, LLDPE, OPA, ALU, PE	
5 Bottle	PET	
6 Base	PP	

2. POLYKEG PRO WITHOUT BAG

Component	Material	Symbol
1 Seal	PP	
2 Valve	Other plastic	
3 Handle	PP	
4 Dip tube	PP	
5 Bottle	PET/MXD6	
6 Base	PP	

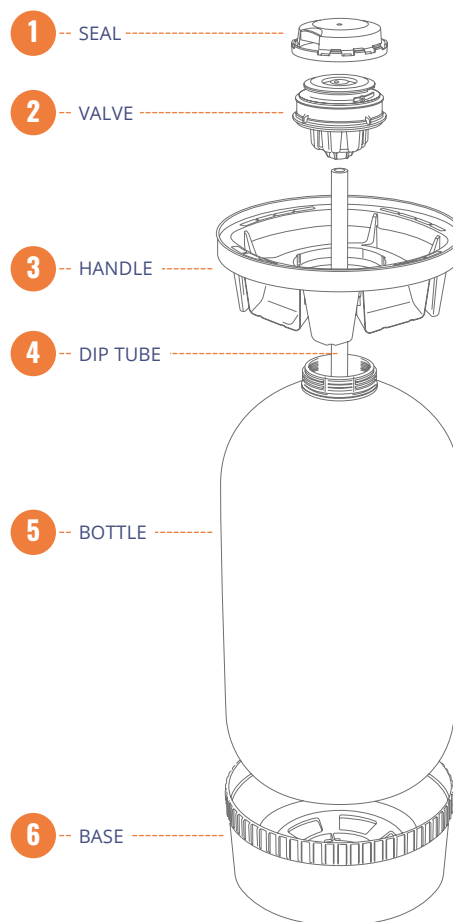
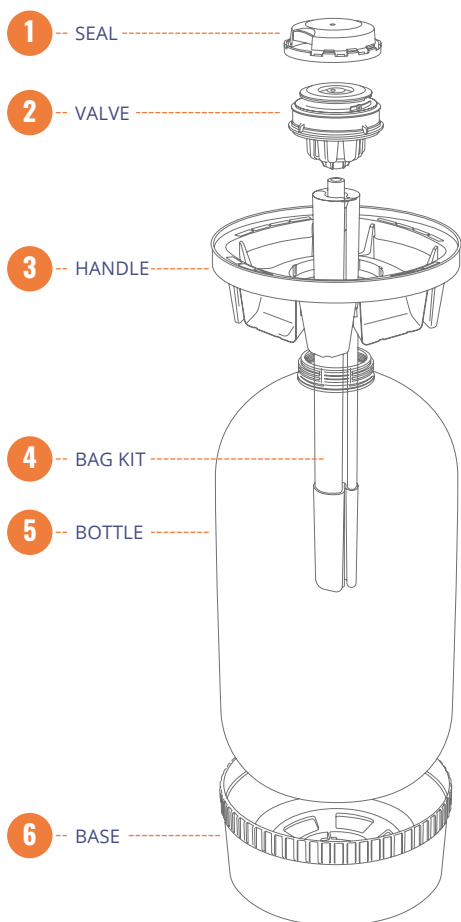



MADE IN ITALY



POLYKEG SRL

Via Pietro Nenni, 51 - 24050 Calcinato (BG) Italy
T +39 035 4522245 | Fax +39 035 4522914
info@polykeg.it

POLYKEG ESPAÑA S.L.U.

CTRA de Vilafranca del Penedés a Fontrubi, KM. 6
08735 Vilobi del Penedés - (Barcelona) Spain
T +34 935 242 560 | sales@polykeg.es

POLYKEG UK LIMITED

3 Hutton Close - South Church Enterprise Park
Bishop Auckland, County Durham DL14 6XG United Kingdom
T +44 01388 433433 | info@polykeg.co.uk

www.polykeg.com    

PolyKeg SRL is certified:

